

SENNA - nero

Systeme à osmose inverse
Flux direct - Sous évier



Systeme peu
encombrant



90 l/h (± 10%)



DISTRIBUTEUR D'EAU OSMOSÉE

À FLUX DIRECT

PRODUCTION 90 L/H



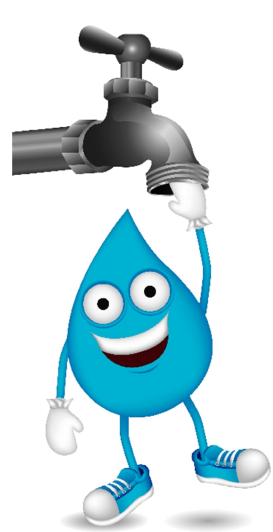

SENNA - nero

Systeme à osmose inverse
Flux direct - Sous évier

LCT-04-plus

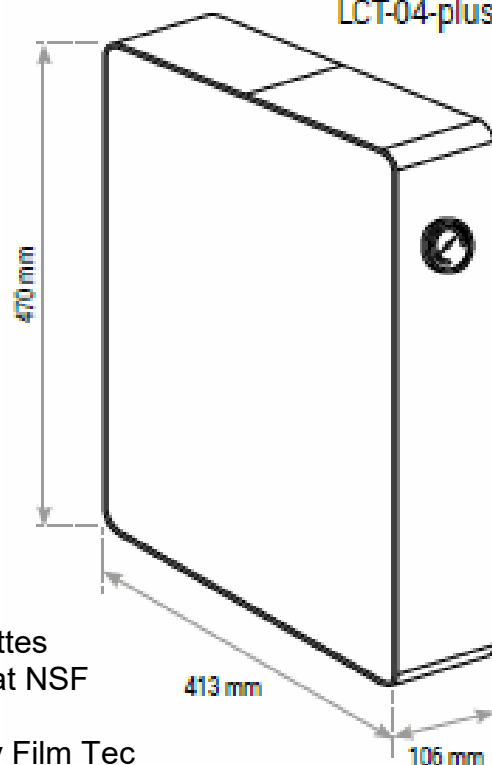

CARACTERISTIQUES TECHNIQUES

Alimentation	230 V - 50Hz
Moteur	180 W - 230 V - 50 Hz
Pompe	300 l/h rotative à palettes Haute pression certificat NSF
Membranes osmotiques	2x 2012 150 GPD TFC (Thin Film Composite) by Film Tec
Filtre	à sédiments en ligne 12", 5 µ
Filtre	charbons actifs en ligne 12", 5 µ
Refroidissement	- Gaz réfrigérant R1 34a - Volume du carbonateur 0,75 lt - consommation 180 W - capacité 4° - 10° 1 8LT/H
Poids vide	13 kg.
Dimensions	106 x 470 x 413 mm. (L - H - P)
Contrôle électronique	- pump start delay - alarme acoustique anti-fuites - alarme filtres à remplacer - nettoyage automatique des membranes toute les 8 heures

Robinetts, accessoires optionnels:

Long col
à une voie.



Mono commande
à 3 voies.



Mono commande
à 3 voies, long col.



Accessoires fournis:

Kit d'installation + robinet

